

Gas ball valve series SF

Gas ball valves of series SF can be supplied with thread or flange connections are suitable to shut-off gas belonging to the first, second and third family and also liquid gas. They are **CE** certified according to norm EN331 for the thread version and according to norm EN13774 for the flanged version.

They are available from Rp 1/4" to 2", full bore or reduced bore, with thread connection according to ISO 7/1 and flanged from DN15 to DN250 according to norm EN1092-2, PN16.

They are equipped with yellow colour for manual operation and on request they can be motorized with electric or pneumatic actuator.



TECHNICAL FEATURES

Body of thread valve	Nichel plated brass
Body of flanged valve	Cast-iron GJS 400-15
O-ring	NBR
Seat	PTFE
Max operating pressure	20 bar thread valve / 16 bar flanged valve
Operating temperature	- 20 ÷ +60°C
Thread connections	Rp 1/4 ÷ Rp 50
Flanged connections	DN15 ÷ DN200
Lever	Steel surrounded by PVC

FEATURES

- Full bore or reduce bore (on request)
- Thread connection F/F or M/F
- Version with lockable lever
- Lever or butterfly in yellow colour

SF = Thread ball valve
SFF/ = Flanged ball valve

100/ = Full bore
151/ = Reduced bore
230/ = Top flange F03/04

Diameter

Thread	Flanged
06 = Rp 1/4	15 = DN15
09 = Rp 3/8	20 = DN 20
15 = Rp 1/2	25 = DN 25
20 = Rp 3/4	32 = DN 32
25 = Rp 1	40 = DN 40
32 = Rp 1.1/4	50 = DN 50
40 = Rp 1.1/2	65 = DN 65
50 = rp 2	80 = DN 80
	100 = DN 100
	125 = DN 125
	150 = DN 150
	200 = DN 200

Model

/FF = Female / female
/MF = Male / female
/LU = lockable
/AN = ANSI flange

SF

100

40

/FF

DIMENSIONS

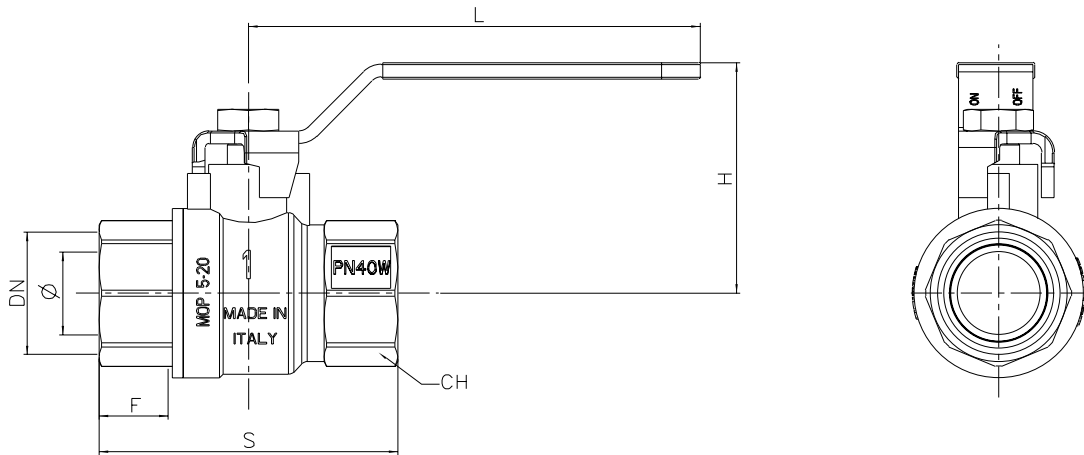

Dimensions (mm)

DN	1/4"	3/8"	1/2"	3/4"	1"	1 1/4"	1 1/2"	2"
Ø	10	10	15	20	25	32	40	50
F	10	10	15	16	19	21	21	26
S1	45	45	63	71	83	92	104	124
S2		54	70	80	92	102	117	137
H	41	41	54	58	66	71	80	88
L	80	80	90	90	125	125	140	140
L1	52	52	62	62	72			
Ch	21	21	26	31	38	48	55	68

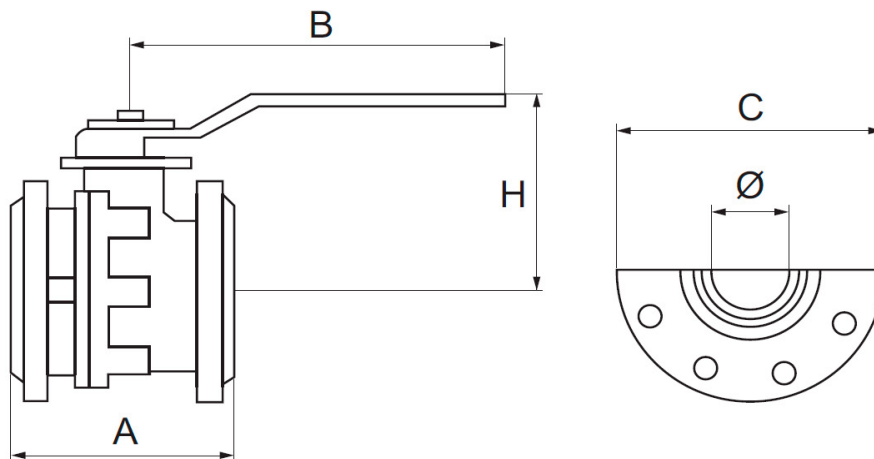

Dimensions (mm)

DN	15	20	25	32	40	50	65	80	100	125	150	200
Ø	15	20	25	32	40	50	63	76	95	120	145	190
A	115	120	125	130	140	150	170	180	190	200	210	400
B	160	160	170	170	230	230	230	280	360	450	560	1000
C	95	105	115	140	150	165	185	200	220	250	285	340
H	84	84	96	101	125	135	143	165	180	225	243	320
Weight (Kg)	2,6	3,3	4,2	5,8	7,5	9	10,5	15,5	18,5	28	38,5	93

INSTALLATION AND OPERATING INSTRUCTIONS

Such control device shall be installed according to valid Rules and on non-corrosive gas distribution networks (natural gas, town gas, LPG) only.

STORAGE

Keep in a dry and cool place.

While storage, keep the valve fully open to avoid damages on seats [Pict. 1].

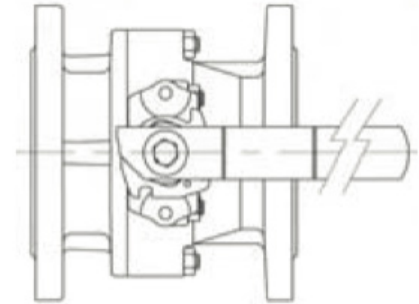

INSTALLATION

Handle with care Insert the sealing between the flanges of the valve and the pipes. Make sure that the sealing is properly placed. Distance S between the flanges and valve gauge shall be equal. Do not use counter flanges bolts to set the pipe close.

Cross tighten clamping bolts onto the pipes [Pict. 2] after valve installation only. Make sure the installation is equipped with expansion joints to avoid breaking or losses due to pipes tensions, vibrations or shifts.

To avoid any damage or break, prevent pressure shocks and apply expansion joints to reduce their effects.

While heating from ambient onto high working temperature, operate intermediate opening and closing manoeuvres (ex. at 40 °C, 60 °C, etc.), to avoid the expansion of the fluid contained between body and flange [valve open] or in the ball passage [valve closed] which could bring damages to the ball and to the seats. Special bleed valve are available for such applications.

By sub-zero temperatures the valve shall be insulated to avoid permanent damages, due to freezing of the fluid between body and ball.

Operate the valves periodically, to avoid slag precipitation on the ball and its seats.

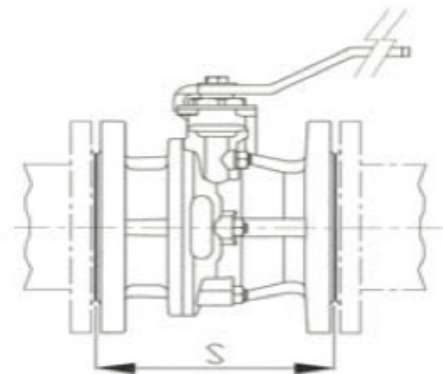

WARNING

Damages to persons may occur by temperature less than 0 °C and higher than 50 °C.

MAINTENANCE

To grant the maximum tighten, O-rings shall be replaced every 24 month and PTFE seats every 48 month, at least. Maintenance period depends on to valve application.

The surface of the valve shall be cleaned periodically, to avoid dust upsurge.

All the reported data are subject to be changed without notice.

from 140918