

Pressure regulator series RG/2MBZ

Pressure regulators of series RG/2MBZ direct operated with compensated obturator are suitable for application on domestic and industrial combustion plants for pressure regulation of gases belonging to the first, second and third family.

They are normally applied on the most common combustion plants like furnaces, boilers, dryers and compact burners. They are equipped with safety device for max and minimum downstream pressure and relief valve.

Pressure regulators of series RG/2MBZ bar are manufactured in conformity to norms EN 88-2 and EN 334, gas directive 2009/142/CE, PED 2014/68/EU and regulation EU 2016/426.

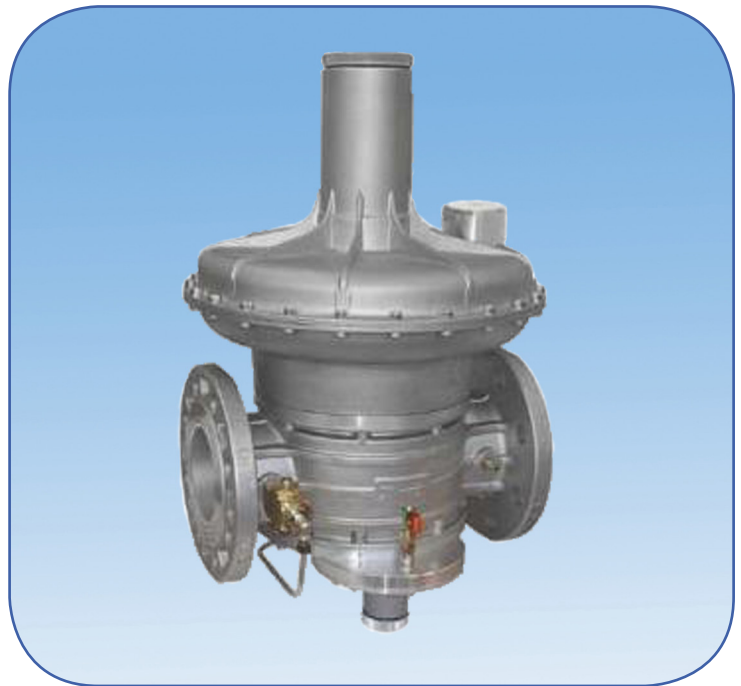

TECHNICAL FEATURES

Valve body	Die-cast aluminium
Thread connection	Rp 1/2 ÷ 2 according to EN10226
Flanged connection PN16	DN32 ÷ 100 according to ISO 7005
Flanged connection ANSI 150	Available on request
Max inlet pressure	5 bar
Downstream pressure	Various ranges of springs available. Please check tables in next pages
Ambient temperature	-20 ÷ +60°C
Mechanical resistance	Group 2

FEATURES

- Installation in horizontal (preferred) or vertical position
- Pressure regulators up to 1" are equipped with a filter
- Easy installation, spring regulation and maintenance
- Accuracy class of downstream pressure : 10
- Safety shut-off valve for minimum and maximum pressure and relief valve
- Special execution for biogas on request

NATURAL GAS FLOW RATE in m³/h

Rp	Downstream pressure	Inlet pressure					
		0,5 bar	1 bar	2 bar	3 bar	4 bar	5 bar
1/2	20	25	27	30	30	30	37
	50	50	50	50	50	50	50
	100	60	62	62	62	62	62
	200	85	85	85	85	85	85
	300	70	100	100	100	100	100
3/4	400	40	90	100	100	100	100
	20	42	42	50	50	50	50
	50	70	70	70	70	70	70
	100	100	100	100	100	100	100
	200	86	100	100	100	100	100
1	300	86	100	100	100	100	100
	400	65	120	120	120	120	120
	20	100	100	100	100	100	100
	50	100	100	100	100	100	100
	100	100	100	100	100	100	100
1.1/4	200	100	100	100	100	100	100
	300	100	100	100	100	100	100
	400	70	120	120	120	120	120
	20	185	350	470	470	470	470
	50	198	370	540	740	740	740
1.1/2	100	150	290	520	815	850	850
	200	100	220	495	790	960	960
	300	110	250	495	890	1100	1100
	20	220	400	740	960	990	990
	50	220	400	740	1090	1240	1240
2	100	200	370	790	1090	1190	1190
	200	135	250	580	890	1340	1390
	300	135	290	590	940	1190	1200
	20	248	446	850	1230	1500	1500
	50	300	446	818	1230	1500	1500
DN65	100	290	440	818	1240	1500	1500
	200	245	372	740	1140	1480	1490
	300	186	320	645	1100	1480	1480
	20	1000	1490	1800	1625	1670	1750
	50	1090	1450	1850	2230	2400	1850
DN80	100	1100	1670	2100	2250	2400	1950
	200	1050	1600	2400	2600	2700	2850
	20	1350	1950	2450	2450	2450	2600
	50	1240	2100	3100	2850	3100	3200
	100	1350	2350	3450	3450	3700	3840
DN100	200	1240	2200	3400	3900	3900	4000
	20	1670	2400	3100	3800	3800	3800
	50	1500	2480	3700	4900	4900	4900
	100	1700	2400	3800	5000	5000	5000
	200	1270	2300	3700	5000	5000	5000

MODELS

Model	Connections Rp and DN*	Downstream pressure (mbar)	OPSO* * (mbar)	UPSO*** (mbar)	Relief range (mbar)
RG/2MBZ	15-20-25/A	20-30	40-90	10-30	10-60
	15-20-25/B	30-90	50-180	20-50	10-60
	15-20-25/C	90-170	120-260	50-110	10-60
	15-20-25/D	170-400	200-550	50-110	40-200
	32-40-50/A	10-22	30-90	7-20	10-20
	32-40-50/B	15-33	30-90	7-20	15-40
	32-40-50/C	32-60	30-120	10-30	15-40
	32-40-50/D	50-95	70-140	10-30	40-80
	32-40-50/E	85-180	90-260	30-50	40-80
	32-40-50/F	150-350	200-550	50-110	50-120
	32-40-50/G	300-500	500-1000	50-110	50-120
	32-40-50/H	500-800	500-1000	50-110	50-120
	60-80/A	13-27	40-110	7-15	15-50
	60-80/B	22-58	40-110	15-25	15-50
	60-80/C	50-130	90-210	25-70	15-50
	60-80/D	110-200	180-350	70-110	20-100
	100/A	13-22	40-110	7-15	15-50
	100/B	18-40	40-110	15-25	15-50
	100/C	35-120	90-210	25-70	15-50
	100/D	110-200	180-350	70-110	20-100

* For flanged connections DN32, 40 and 50 add letter "F" before size. For example RG/2MBZF40...

** OPSO over pressure shut off

*** UPSO under pressure shut off

DIMENSIONS

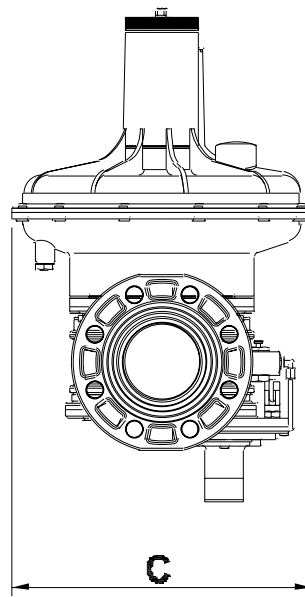
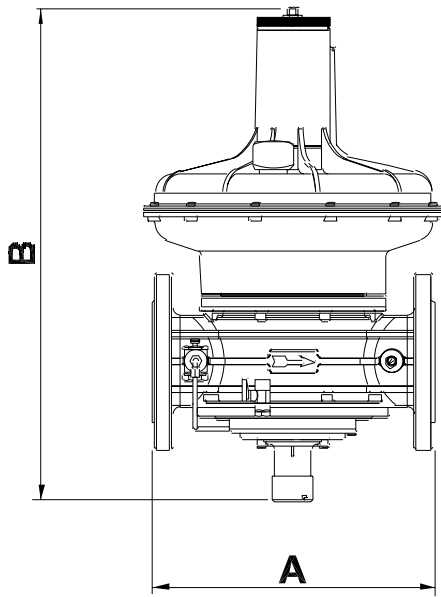
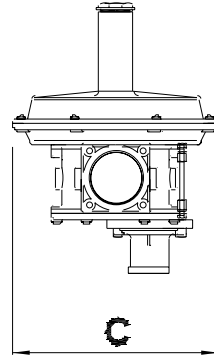
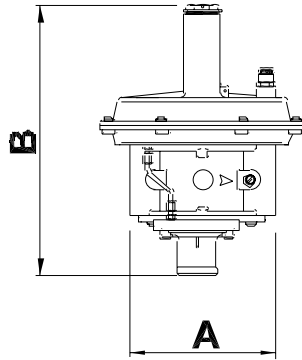
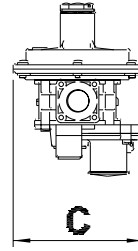
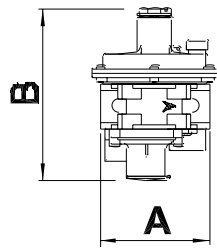

Model	Connection Rp and DN	Dimensions (mm)			Weight (Kg)
		A	B	C	
RG/2MBZ	1/2 - 3/4 - 1	140	190	143	1,3
RG/2MBZ	1.1/4 - 1.1/2 - 2	160	297	225	3,7
RG/2MBZ	DN32,40 and 50	230	330	225	5,3
RG/2MBZ	DN65	290	528	330	15,0
RG/2MBZ	DN80	310	535	330	15,0
RG/2MBZ	DN100	350	561	330	18,0



WARNING

Installation, wiring, regulation and maintenance of the valve must be done exclusively by skill and trained people.

INSTALLATION

- 1.1 The gas supply must be shut off before installation.
- 1.2 Check that the line pressure DOES NOT EXCEED the maximum pressure stated on the product label.
- 1.3 The regulator is normally installed before the user. It must be installed with the arrow on the body towards the user.
- 1.4 It can be installed in any position but it is preferable the installation with the spring in vertical position. On outside the regulator, downstream of it, there is a checking pressure-tap for the control of the regulation pressure.
- 1.5 During installation take care not to allow debris or scraps of metal to enter the device.
- 1.6 If the device is threaded check that the pipeline thread is not too long; overlong threads may damage the body of the device when screwed into place.
- 1.7 Do not use the spring casing for leverage when screwing into place; use the appropriate tool.
- 1.8 If the device is flanged check that the inlet and outlet counter-flanges are perfectly parallel to avoid unnecessary mechanical stresses on the body of the device. Also calculate the space needed to fit the seal. If the gap left after the seal is fitted is too wide, do not try to close it by over-tightening the device's bolts.
- 1.9 Always check that the system is gas-tight after installation.

CALIBRATION

- 2.1 Before starting the system, pay attention that the standard regulation spring is suitable with the needed regulation pressure.
- 2.2 After removing the cap, calibrate the regulator at the minimum (completely unscrewed), then start the system and checking the regulation pressure, screw the regulator up to the needed pressure.