

Stainless steel flexible compensator for gas

Metal flexible joints suitable for the installation of gas burners, using air under pressure, enable vibration isolation and compensate for the misalignment of ducting.

The soul of the joint is the metallic bellows, achieved without helical winding, but with undulations on parallel stainless steel tube.

Flexible hoses are designed to absorb axial [h], angular [α] and lateral [e] movements as well as vibrations.

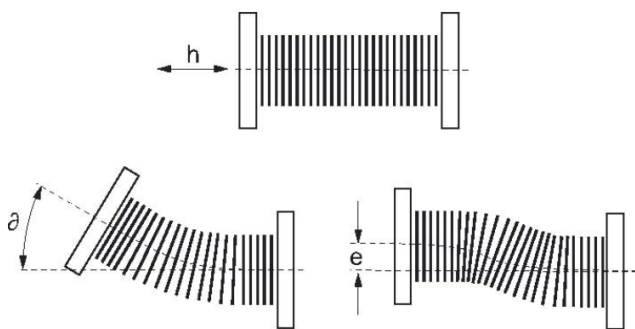

In order to avoid damages to bellow, prevent torsional loads on hoses.

GMM joints are fitted with threaded male-male connections; GFL and St.FB joints with flanged connections. Bellows is in stainless steel AISI 321.

Flanges in carbon steel are loose, enabling alignment of the holes of flanges and counter-flanges, avoiding detrimental tensions and facilitating their assembly.



TECHNICAL FEATURES

Series	Max. temperature	Max. pressure	Connections
GMM	250 °C	2,5 bar	Threaded cone-shaped ISO R7/1
St. FB	300 °C	10 bar	Flanged PN 10 EN 1092
GFL	250 °C	2,5 bar	Flanged PN 16 EN 1092

GMM

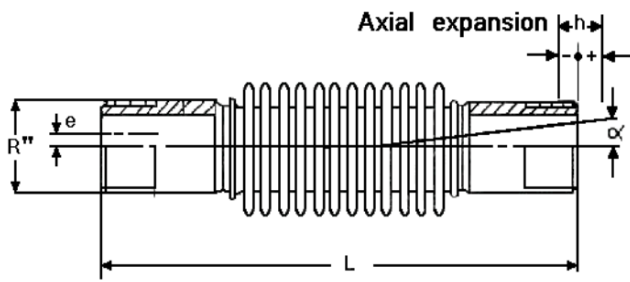

St.FB

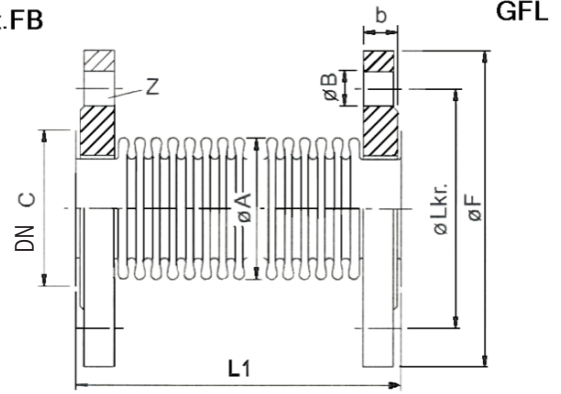

GFL

Model	Threaded connections (Rp)	Max. pressure (bar)	Max deflection				Length L (mm)
			Axial		Angular ϑ +/- (o)	Lateral e +/- (mm)	
			h total mm	h +/- mm			
GMM15	1/2	2,5	12	6	50	5	170
GMM20	3/4	2,5	16	8	50	8	180
GMM25	1	2,5	16	8	50	10	190
GMM32	1 1/4	2,5	20	10	50	14	200
GMM40	1 1/2	2,5	30	15	45	14	210
GMM50	2	2,5	30	15	30	12	240
GMM65	2 1/2	2,5	40	20	30	12	250

Model PN 10 (bar)	DN	Max. deflection				Length L1 (mm)	Flange PN 10					
		Axial h +/- (mm)	Angular ϑ +/- (o)	Lateral +/- (o)	In any direction (mm)		\varnothing A mm	\varnothing F mm	b mm	\varnothing LKr mm	\varnothing B mm	Hole (Z)
St.FB 50	50	15	22	7	1,0	150	75	165	16	125	18	4
St.FB 65	65	20	25	8,5	1,0	155	90	185	16	145	18	4
St.FB 80	80	22,5	20	8,5	0,9	165	110	200	18	160	18	8
St.FB 100	100	22,5	19	7	0,9	170	133	220	18	180	18	8
St.FB 125	125	22,5	16	6,5	0,7	185	157	250	18	210	18	8
St.FB 150	150	32,5	15	8	0,7	205	190	285	18	240	23	8
St.FB 200	200	32,5	12	8	0,7	235	250	340	20	295	23	8
St.FB 250	250	32,5	12	6,5	0,7	240	300	395	22	350	23	12

Model 2,5 bar	DN	Max. deflection				length L1 mm	Flange PN 16					
		Axial h +/- mm	Angular ϑ +/- (o)	Lateral +/- (o)	In any direction mm		\varnothing A mm	\varnothing F mm	b mm	\varnothing LKr mm	\varnothing B mm	Hole (Z)
GFL 50	50	45	22,5	11	1,0	150	75	165	19	125	18	4
GFL 65	65	45	22,5	11	1,0	155	90	185	20	145	18	4
GFL 80	80	45	22,5	10	0,9	165	110	200	20	160	18	8
GFL 100	100	45	22,5	10	0,9	175	133	220	22	180	18	8

All the reported data are subject to be changed without notice.

from 181011