

# Turbine gas flow quantometer series CPT

CPT quantometers, designed in order to provide a reliable and inexpensive measuring device [non fiscal], with features alike those of fiscal turbine meter, are maintenance free and can be logged onto external instrumentation.

Quantometers fulfil various requirements of industrial metering to control the flow of gas precisely and therefore optimise the use of energy.

Turbine gas meters work on the principle of the ratio among gas moving through the meter and wheel speed. A mechanical/magnetic coupling activates the measuring unit on the top of the quantometer reporting the gas volume at operating.



## TECHNICAL FEATURES

<b>Meter body</b>	Aluminium or steel (DN200)
<b>Pressure rating</b>	PN16, PN20, ANSI 150
<b>Thread connection model CPT-01</b>	Rp 1 and 1.1/4 (male), Rp 1.1/2 and 2 (female)
<b>Sandwich connection model CPT/QT</b>	DN40 up to DN200
<b>Ratio</b>	Qmin/Qmax ratio 1:20
<b>Ambient temperature</b>	-25 °C up +70 °C
<b>Gas temperature</b>	-20 °C up +60 °C
<b>Mechanical index</b>	Routable axially by 350°
<b>Operating position</b>	Horizontal or vertical
<b>Measurement accuracy</b>	Qt/Qmax < ± 1,5%, Qt/Qmin < ± 3,0%
<b>Enclosure</b>	IP 65

## FEATURES

- Measuring cartridge apart from the body and sandwich shape of the meter, to warrant high resistance against mechanical stress due to lack of alignment of the flanges
- Minimum pressure loss through high precision gaskets and tolerance range of each measuring part
- Operating pressure worth detectable by the precision socket on the meter body
- Adjustable mechanical index of the meter reporting the volume at operating conditions [pressure and temperature], to assist the measure and the connection of sensors
- Wide range of external device like volume correctors, data loggers, data transmission systems

## FLOW CHART

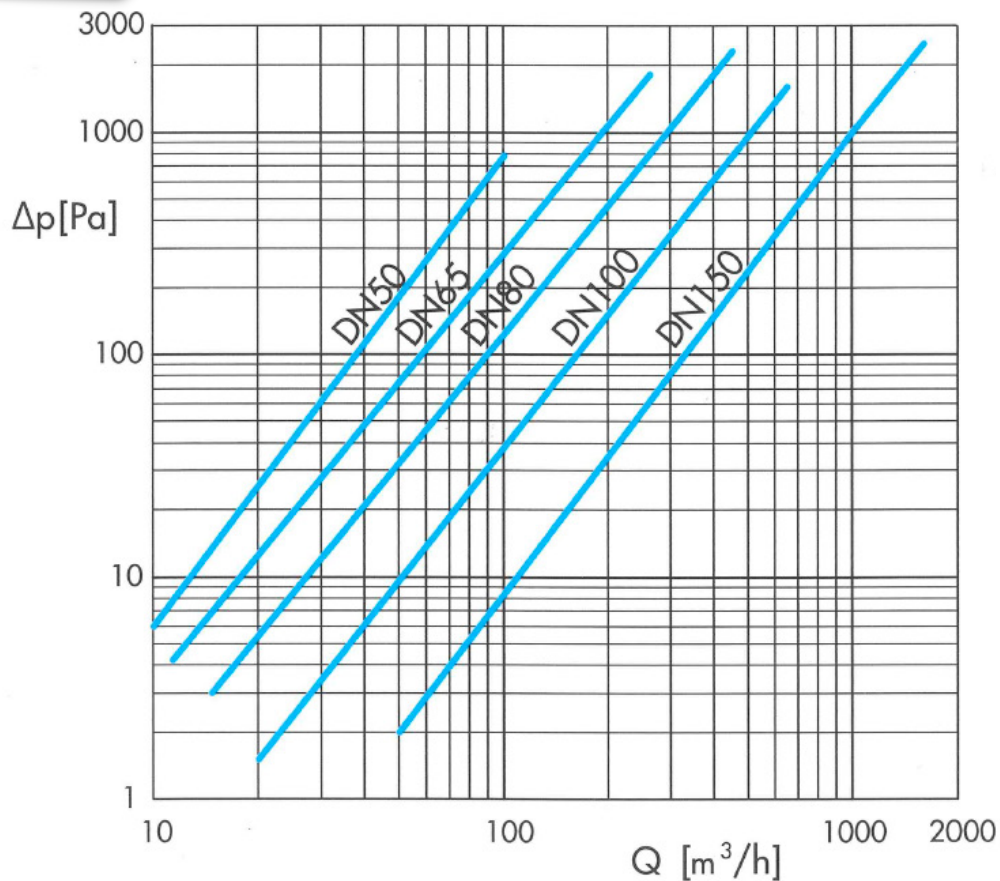

The pressure loss during the gas flow through the meter is calculated at atmospheric conditions. In order to get the operation conditions, refers to following formula:

$$\Delta p_1 = \left( \frac{\rho_s}{\rho_a} \right) \bullet \left( \frac{p_m + p_s}{p_s} \right) \bullet \Delta p$$

- $\Delta p_1$  = pressure loss at  $p_m$
- $\Delta p$  = pressure loss from the diagram
- $p_m$  = operating pressure in bar
- $\rho_s$  = standard gas density in  $\text{kg/m}^3$
- $\rho_a$  = standard air density [ $1,2 \text{ kg/m}^3$ ]
- $p_s$  = atmospheric pressure [ $1,01325 \text{ bar}$ ]

## MODELS

### CPT - 01 THREAD CONNECTION

Model	DN	G	Interal thread	Min flow $Q_{\min}$	Max flow $Q_{\max}$	LF pulse rate	HF1, HF2 pulse rate	Hf3 pulse rate
			Rp	$\text{m}^3/\text{h}$	$\text{m}^3/\text{h}$	Pulse / $\text{m}^3$	Pulse / $\text{m}^3$	Pulse / $\text{m}^3$
QT16-25	25	16	1, 1.1/4	2,5	25	10	9770	113585
QT25-25		25	1	4	40		8710	101275
QT25-32	32	25	1.1/4	4	40	10	8925	103755
QT40-40	40	40	1.1/2	6	65	10	2610	94830
QT65-40		65		10	100		2610	94830
QT40-50	50	40	1.1/2	6	65	10	2610	94830
QT65-50		65		10	100		2610	94830

# MODELS

## CPT/QT SANDWICH

Model	DN	G	Min flow	Max flow	LF pulse rate	HF1, HF2	HF3
			Q <sub>min</sub>	Q <sub>max</sub>	Pulse / m <sup>3</sup>	pulse rate	pulse rate
			m <sup>3</sup> /h	m <sup>3</sup> /h	Pulse / m <sup>3</sup>	Pulse / m <sup>3</sup>	Pulse / m <sup>3</sup>
QT40-40	40	40	6	65	10	2610	94830
QT65-40		65	10	100		2610	94830
QT40-50	50	40	6	65	10	2610	94830
QT65-50		65	10	100		2610	94830
QT65-65	65	65	8	100	10	1081	42560
QT100-65		100	8	160	1	1081	42560
QT100-80	80	100	8	160	1	1081	42560
QT160-80		160	13	250		844	30650
QT250-80		250	20	400		470	17060
QT160-100	100	160	13	250	1	692	16780
QT250-100		250	20	400		692	16780
QT400-100		400	32	650		401	9720
QT400-150	150	400	32	650	1	227	6870
QT650-150		650	50	1000		227	6870
QT1000-150		1000	80	1600		0,1	129
QT650-200	200	650	50	1000	1	114	3110
QT1000-200		1000	80	1600	0,1	116	3170
QT1600-200		1600	130	2500	67	2025	

# DIMENSIONS

DN	A1	A2	A3	G	H	Z inch	Weight Kg
25	-	200	250	199	252	1, 1.1/4	4,6
32	-	200	250	199	252	1.1/4	4,6
40	160	-	-	199	252	1.1/2	4,4
50	160	-	-	199	252	2	4,4

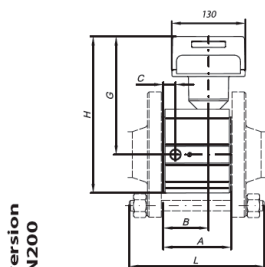
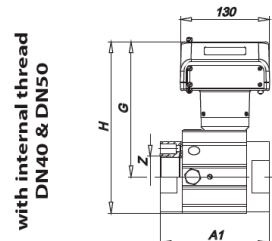
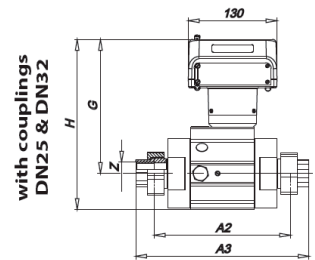

Sandwich version  
DN40 - DN200

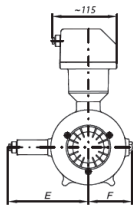

Dimensions E & F for all types

DN	A	B	C	D	E	F	G	H	J	K	L	Weight
	mm	mm	mm	mm	mm	mm	mm	mm	mm		mm	Kg
50	100	65	18	32	158	74	199	252	78	4xM16	200	3,6
65	120	80	21	38	170	86	211	278	90	4xM16	220	5,1
80	120	80	21	38	170	86	211	278	90	8xM16	220	5,3
100	150	100	29	53	185	100	225	305	105	8xM16	250	7,4
150	180	127	50	76	210	125	243	351	130	8xM20	300	11,6
200	200	146	56	83	225	140	272	407	145	12xM20	320	48,5

## FEATURES PULSE SENSOR

As an option the meters can be provided with maximum 7 pulse transmitters. In standard version there are no 2 LKF - low frequency reed contact pulse sensor.

As option there are :

- no 2 LFI - low frequency inductive pulse sensor (Namur)
- no 2 HF - inductive pulse sensors in the index head (Namur) - HF1, HF2
- no 1 HF - inductive pulse sensors in the meter body (Namur) - HF3

Pulse sensor pin numbering in sockets 1 and 2 installed in the index head. The sockets match the TUCHEL plug No C091 31H006 100 2

Connection lead no	Socket 1 pulse sensor	Socket 2 pulse sensor
1 - 4	LFK 1 (standard)	LFK 2
2 - 5	LFI 1	LFI 2
3 - 6	HF1 or AFK	HF2

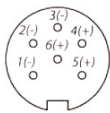

Pulse sensor pin numbering of the HF3 pulse transmitter's socket installed in the body. The sockets match the TUCHEL plug No C091 31D004 100 2

Connection lead no	HF over turbine wheel
1 - 2	Not used
3 - 4	HF3

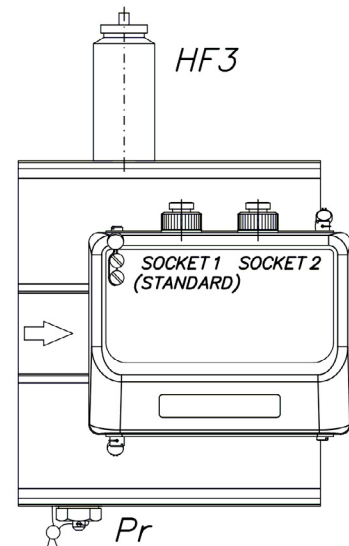
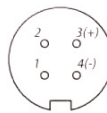

## INSTALLATION AND OPERATING INSTRUCTIONS

**Installation, connection, adjustment and maintenance of the quantometer must be carried out exclusively by skilled and authorized service technicians.**

Meters should be supplied to installation area in their original package.

Meters should be handled with care and protected against falls, rain, snow, humidity or any other weather element.

Before installing the meter make sure that the pipeline is free of impurities and perfectly aligned with the meter body to avoid mechanical stress. A 10  $\mu$  strainer is recommended on upstream pipe.

When designing brand new systems, it is recommended to install a temporary conic filter on the inlet pipe.

Sealing material must be applied to avoid any concern onto gas flow.

The flow direction indicated by the arrow on the meter housing must be respected.

When used outdoors, the meter should be protected against direct weather effects.

By starting the gas flow through the installation, the valve should be opened slowly to ensure a steady growth of the pressure.

All the reported data are subject to be changed without notice.

form140918