

Motorized butterfly valves electronic or pneumatic actuator

Motorized butterfly valves of the series BSV and BFV are used on combustion systems as control valves. They are used in industrial field for gas or air regulation on ovens, industrial boilers and any machine equipped with the different types of burners available on the market.

Motorized butterfly valves of the series BSV and BFV are suitable for all gases belonging to the first, second and third family and for air. They are DVGW-approved according to the norm EN161 and to EMC electromagnetic compatibility with CE certification.

BSV type: installation with two threaded flanges EN 10226 from Rp 3/4 to Rp 2

BFV Type: installation between two flanges ISO 7005 PN 10/16 from DN 25 to DN 250.

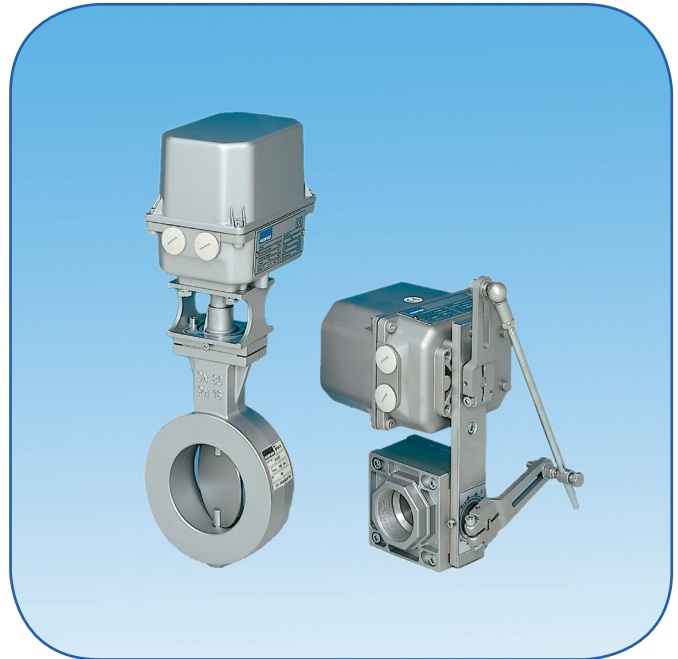

TECHNICAL FEATURES

Body	Aluminium
Stem	Stainless steel AISI 303
Butterfly disc	Aluminium or AISI 304
Stem seal	"O" ring in BUNA "N" or viton
Operating pressure	max 500 mbar
Ambient temperature for gas	-10 ÷ +60 °C
Ambient temperature for air	-10 ÷ +80 °C
Temperature on request	-10 ÷ +110 °C air
Temperature on request	-10 ÷ +200 °C air
Leakage	Minimum leakage
Control ratio	10:1

Body and cover	Die-cast aluminium
Voltage	230V, 115V, 24V ac / 50-60 Hz
Nominal load	4,5 - 7 VA
Input signal	4 ÷ 20 mA or 0 ÷ 10V dc
Output signal	4 ÷ 20 mA or 0 ÷ 10V dc
Rotation time	7,5 ÷ 60 seconds at 50 Hz
Duty cycle	Continuous 100%
Rotation angle	Adjustable 20 ÷ 90°
Enclosure	IP54 - IEC 529, IP65 (on request)
Aux end switches rating	0,5A / 48V dc and ac
Cable gland	2 x Pg 13,5

FEATURES

- Sturdy, compact construction, especially suitable for industrial applications
- Installation in any position
- Mechanical position indicator
- Motor cams easily adjustable
- Special executions of the valve body available:
 - 1 or 2 internal reductions with respect to the valve nominal diameter
 - Butterfly disk made of stainless steel AISI 304 for air temperatures up to 200 °C
 - 1 or 2 feedback potentiometer: from 150 ohm to 5 kohm
 - Input signal 4 ÷ 20 mA or 0 ÷ 10V dc

WIRING DIAGRAM

For electric connection of motorized butterfly valves with AB1 or AR2 gear motor please refer to the respective technical bulletins.

MODELS

BFV = Flanged butterfly valve

BSV = Thread butterfly valve

Diameter	BSV	BFV
20	= Rp 3/4	/
25	= Rp 1	DN 25
32	= Rp 1 1/4	DN 32
40	= Rp 1 1/2	DN 40
50	= RP 2	DN 50
65	= /	DN 65
80	= /	DN 80
125	= /	DN 125
150	= /	DN 150
200	= /	DN 200
250	= /	DN 250

Adaptor

- P1** = AB1 shaped - axial
- P2** = AR2 shaped - axial
- P5** = AB1 shaped with lever axial
- P15** = Pneumatic actuator
- T1** = AB1 in tandem
- T2** = AR2 in tandem

Actuator model

- AB1** = AB1 actuator
- AR2** = AR2 actuator
- AP - DE** = Double effect pneumatic actuator
- AP - SE** = Simple effect pneumatic actuator

Supply voltage

- A** = 24V ac / 50-60Hz
- B** = 115V ac / 50-60Hz
- C** = 230V ac / 50-60Hz
- B/A** = with transformer 115V/24V ac (+6%-10% / 50-60Hz)
- C/A** = with transformer 230V/24V ac (+6%-10% / 50-60Hz)

Rotation time per 90° at 50 Hz

- 0** = 7,5 s
- 1** = 15 s
- 2** = 30 s
- 3** = 60 s

Potentiometer

- 00** = Not foreseen
- 13** = 1 kohm
- 15** = 2,5 kohm
- **** = other models available (check actuator tech specs)

Auxiliary switch

- 0** = not foreseen (only model 230V 60s)
- 2** = 2 (standard)

Accessories

- S** = Control station AUTO/MAN
- O** = Position indicator for AB1 on top cover
- E2** = Input 0÷10V dc or 4÷20 mA, output 0-10V dc
- E4** = Input 0÷10V dc
- E5** = Input 4÷20 mA
- E7** = Input 4÷20 mA, output 0÷10V dc
- **** = other models available (check actuator tech specs)

BSV

25

P1

AB1

C

3

13

0

S

BUTTERFLY VALVE BSV

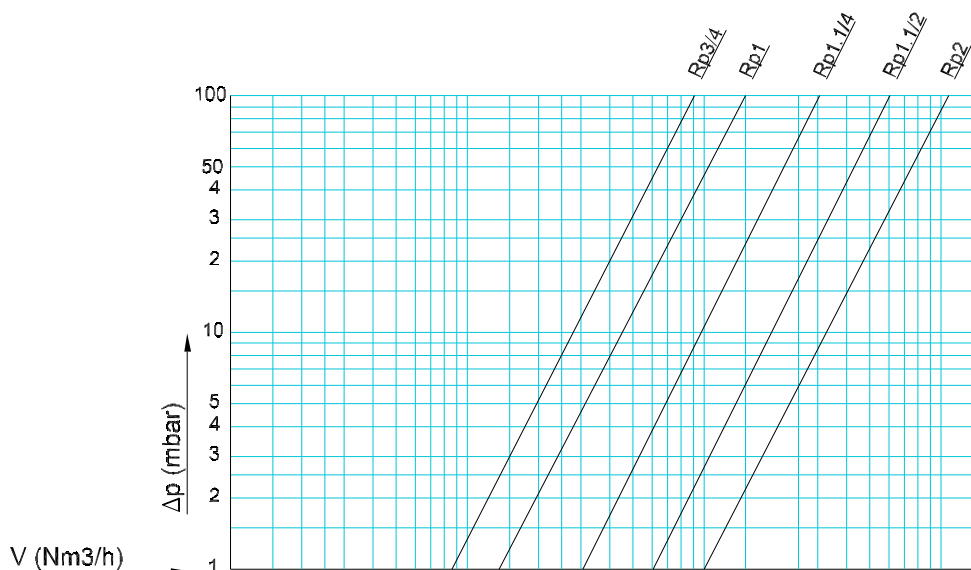

Aria	dv=1	1 2 3 4 5 6 8 10 2 3 4 5 6 8 100 2 3 4 5 6 8 1000
Air	dv=1	1 2 3 4 5 6 8 10 2 3 4 5 6 8 100 2 3 4 5 6 8 1000
Metano	dv=0,64	1 2 3 4 5 6 8 10 2 3 4 5 6 8 100 2 3 4 5 6 8 1000
Methane	dv=0,64	1 2 3 4 5 6 8 10 2 3 4 5 6 8 100 2 3 4 5 6 8 1000
Gas di citta'	dv=0,45	1 2 3 4 5 6 8 10 2 3 4 5 6 8 100 2 3 4 5 6 8 1000 2
Town gas	dv=0,45	1 2 3 4 5 6 8 10 2 3 4 5 6 8 100 2 3 4 5 6 8 1000 2
Propano	dv=1,56	1 2 3 4 5 6 8 10 2 3 4 5 6 8 100 2 3 4 5 6 8 1000
Propane	dv=1,56	1 2 3 4 5 6 8 10 2 3 4 5 6 8 100 2 3 4 5 6 8 1000
Butano	dv=2,09	1 2 3 4 5 6 8 10 2 3 4 5 6 8 100 2 3 4 5 6 8
Butane	dv=2,09	1 2 3 4 5 6 8 10 2 3 4 5 6 8 100 2 3 4 5 6 8
G.P.L.	dv=1,70	1 2 3 4 5 6 8 10 2 3 4 5 6 8 100 2 3 4 5 6 8 1000
L.P.G.	dv=1,70	1 2 3 4 5 6 8 10 2 3 4 5 6 8 100 2 3 4 5 6 8 1000

BUTTERFLY VALVE BFV

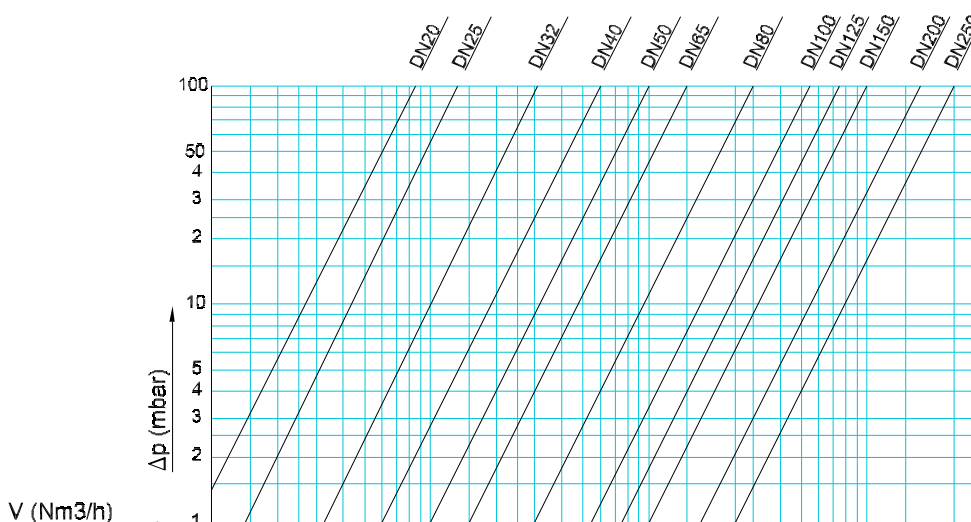

Aria	dv=1	10 20 30 40 50 60 80 100 2 3 4 5 6 8 1000 2 3 4 5 6 8 10000 2 3
Air	dv=1	10 20 30 40 50 60 80 100 2 3 4 5 6 8 1000 2 3 4 5 6 8 10000 2 3
Metano	dv=0,64	10 20 30 40 50 60 80 100 2 3 4 5 6 8 1000 2 3 4 5 6 8 10000 2 3
Methane	dv=0,64	10 20 30 40 50 60 80 100 2 3 4 5 6 8 1000 2 3 4 5 6 8 10000 2 3
Gas di citta'	dv=0,45	10 20 30 40 50 60 80 100 2 3 4 5 6 8 1000 2 3 4 5 6 8 10000 2 3 4
Town gas	dv=0,45	10 20 30 40 50 60 80 100 2 3 4 5 6 8 1000 2 3 4 5 6 8 10000 2 3 4
Propano	dv=1,56	10 20 30 40 50 60 80 100 2 3 4 5 6 8 1000 2 3 4 5 6 8 10000 2
Propane	dv=1,56	10 20 30 40 50 60 80 100 2 3 4 5 6 8 1000 2 3 4 5 6 8 10000 2
Butano	dv=2,09	10 20 30 40 50 60 80 100 2 3 4 5 6 8 1000 2 3 4 5 6 8 10000 2
Butane	dv=2,09	10 20 30 40 50 60 80 100 2 3 4 5 6 8 1000 2 3 4 5 6 8 10000 2
G.P.L.	dv=1,70	10 20 30 40 50 60 80 100 2 3 4 5 6 8 1000 2 3 4 5 6 8 10000 2
L.P.G.	dv=1,70	10 20 30 40 50 60 80 100 2 3 4 5 6 8 1000 2 3 4 5 6 8 10000 2

DIMENSIONS

BSV threaded butterfly valve DN 20 ÷ DN 50 with AB1 gear motor

Direct connection on the same axis - Axial adaptor model AP1 [Drawing A.21.001]

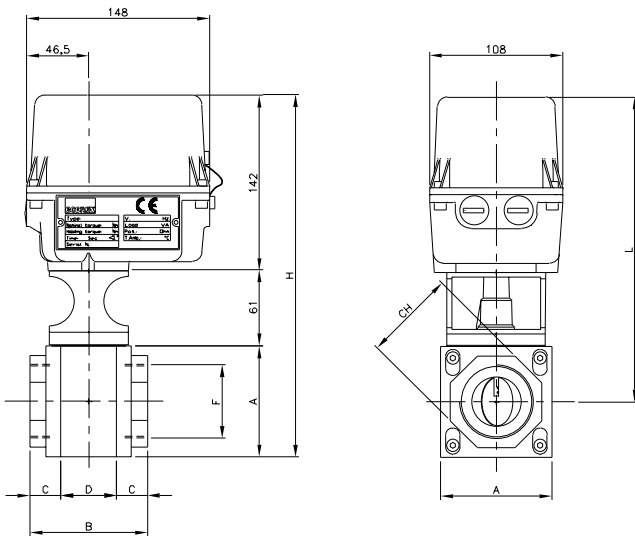

DN	F	CH	A	B	C	D	H	L
20	3/4	42	60	86	22	42	263	233
25	1	42	60	86	22	42	263	233
32	1 1/4	60	90	95	25	45	293	248
40	1 1/2	60	90	95	25	45	293	248
50	2	74	90	95	25	45	293	248



Tandem connection - Adaptor model T1 [Drawing A.21.004]

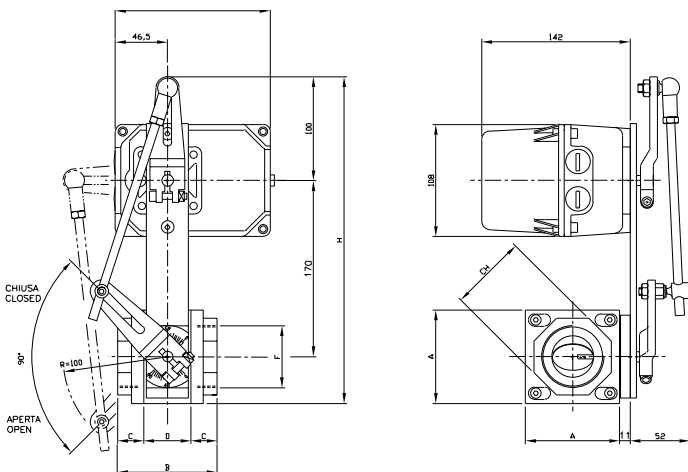

DN	F	CH	A	B	C	D	H
20	3/4	42	60	86	22	42	300
25	1	42	60	86	22	42	300
32	1 1/4	60	90	95	25	45	315
40	1 1/2	60	90	95	25	45	315
50	2	74	90	95	25	45	315



BFV flanged butterfly - wafer type - with AB1 gear motor

Direct connection on the same axis - Axial adaptor model AP1 [Drawing A.11.001]

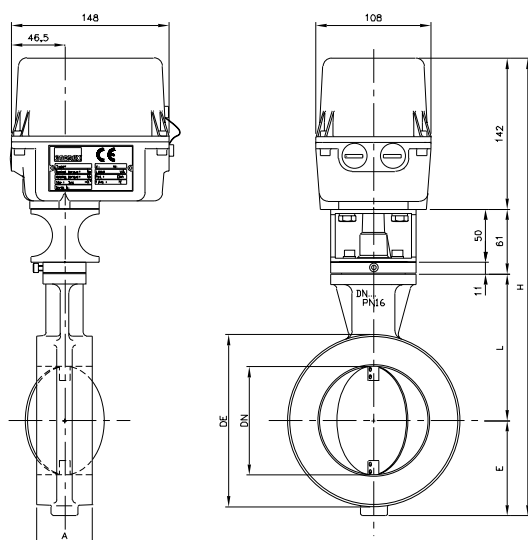

DN	25	32	40	50	65	80	100	125	150
DE	71	82	92	107	126	141	162	192	217
A	40	40	40	43	46	46	52	56	56
E	35	41	46	54	73	77	89	106	118
L	81	85	89	100	108	128	138	149	162
H	320	329	338	357	411	408	430	458	483

Tandem connection - Adaptor model T1, T2 and T3 [Drawing A.11.004]

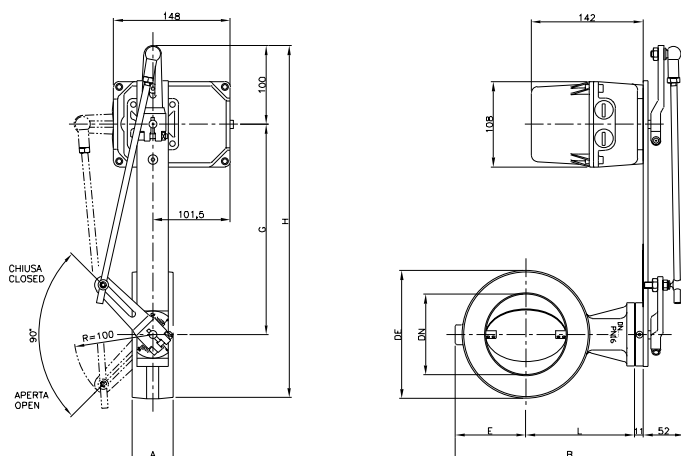

DN	25	32	40	50	65	80	100	125	150
DE	71	82	92	107	126	141	162	192	217
A	40	40	40	43	46	46	52	56	56
B	180	189	198	217	244	268	290	318	343
E	35	41	46	54	73	77	89	106	118
G	170	170	170	170	225	225	225	325	325
L	81	85	89	100	108	128	138	149	162
H	305	311	316	323	388	395	406	521	533

BFV flanged butterfly - wafer type - with AR2 gear motor

Direct connection on the same axis - Axial adaptor model AP2 [Drawing A.12.001]

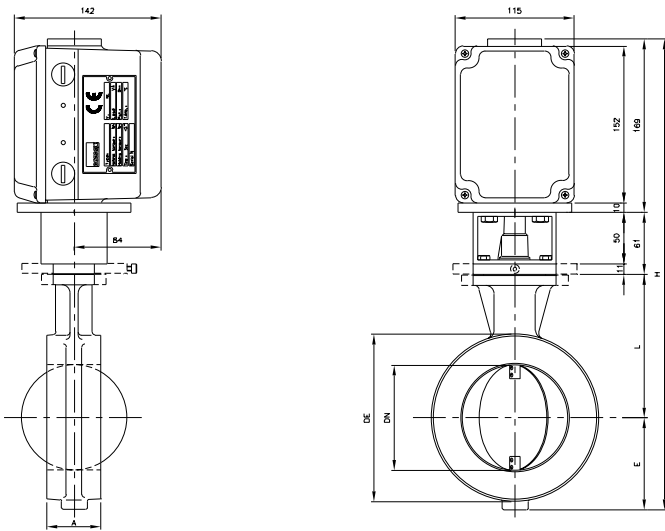

DN	25÷50	65	80	100	125	150	200	250*
DE	on request	126	141	162	192	217	272	330
A		46	46	52	56	56	60	68
E		73	77	89	106	118	147	165
L		108	128	138	149	162	187	225
H		411	435	457	485	510	564	620



Tandem connection - Adaptor model T3 for DN 65 ÷ 100 or model T4 for DN 125 ÷ 250 [Drawing A.12.004]

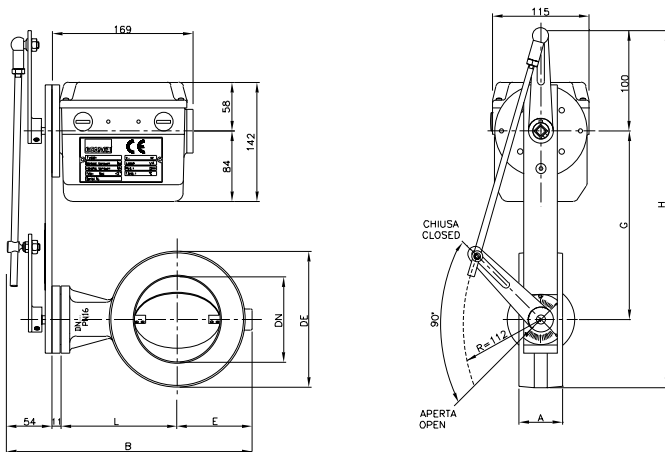

DN	65	80	100	125	150	200	250*
DE	126	141	162	192	217	272	330
A	46	46	52	56	56	60	68
B	246	270	292	320,5	345	399	455
E	73	77	89	106	118	147	165
G	225	225	225	325	325	325	325
L	108	128	138	149,5	162	187	225
H	388	395,5	406	521	533,5	561	590

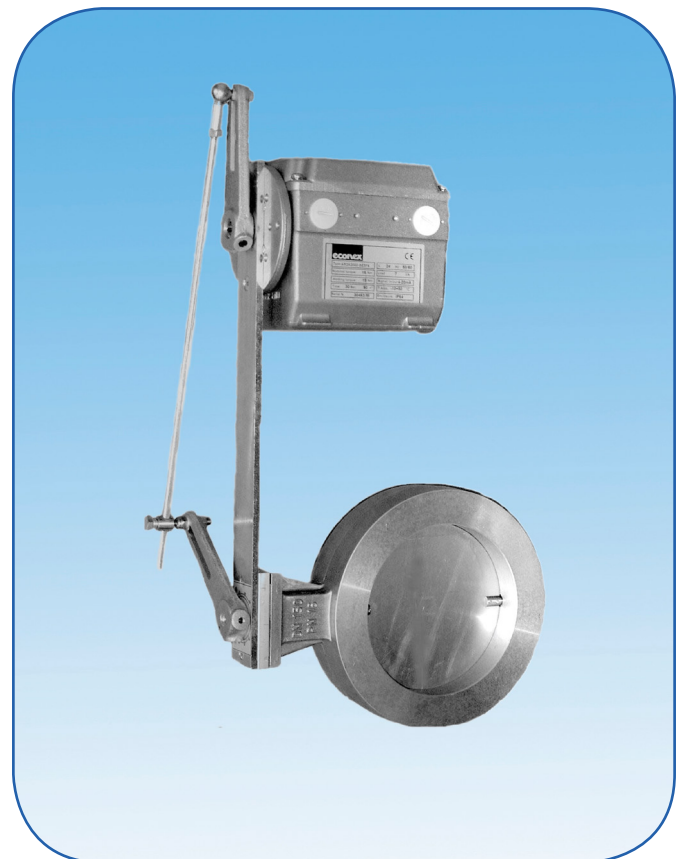

BFV Flanged butterfly valve water type with pneumatic actuator

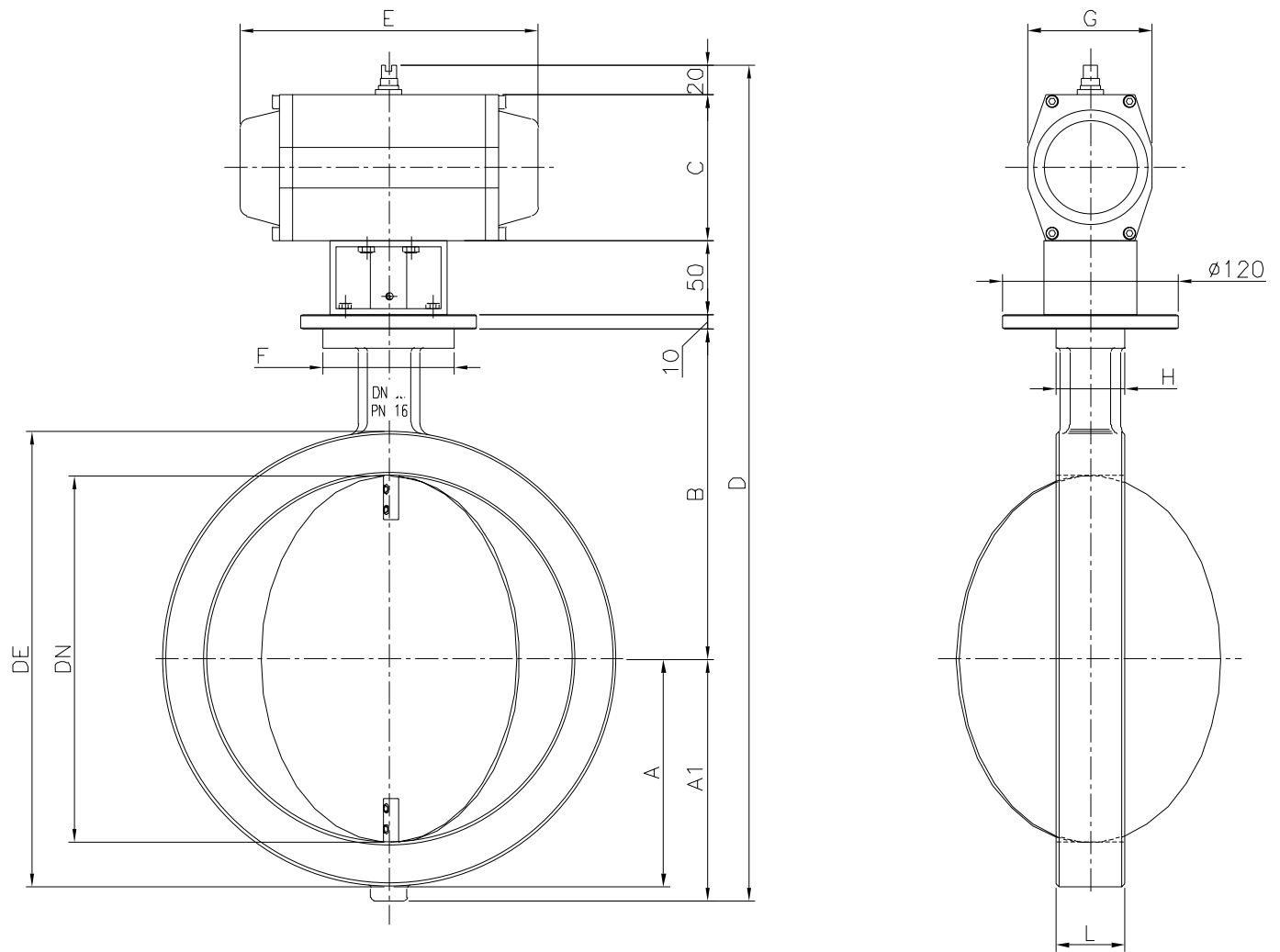

Dimensions in mm

DN	25	32	40	50	65	80	100	125	150	200	250
DE	71	82	92	107	126	141	162	192	217	272	330
A	35,5	41	46	54	/	/	/	/	/	136	165
A1	/	/	/	/	73	77	89	106	118	/	/
B	81,5	85	89,5	100,5	108	128	137	149,5	162	187	225
C	67	67	57	67	67	67	67	83	83	83	100
D	264	273	282,5	301,5	328	352	374	418,5	443	486	570
E	137	137	137	137	137	137	137	150	150	150	204
F	80	80	80	80	80	80	80	80	80	Ø 90	Ø 90
G	60	60	60	60	60	60	60	73	73	73	85
H	40	40	40	40	40	40	40	40	40	Ø 90	Ø 90
L	40	40	40	43	46	46	52	56	56	60	68



WARNING

PLEASE READ THE OPERATING INSTRUCTIONS BEFORE USE!

THIS EQUIPMENT MUST BE INSTALLED ACCORDING TO THE PRESCRIPTIONS IN FORCE!

Installation, connections, adjustment and maintenance of the valve must be carried out exclusively by skilled and authorized service technicians. Non proper installation, adjustment, changes, use and maintenance may cause damages to the personnel or to the equipment. Consequently it is necessary to respect strictly the following instructions and local prescriptions for both the installation of electric devices and of gas systems.

1. INSTALLATION

- 1.1 Make sure that all operating data indicated on the valve plates correspond to those of the system.
- 1.2 When installing the valve be sure that there is sufficient clearance above the gear cover and that it can be easily accessible in order to perform manual servicing, automatic servicing by means of a gear motor or servicing by means of levers.
- 1.3 For the valves of the BSV series proceed as follows:
remove the protection plugs from the threaded flanges,
screw the threaded flanges to the inlet and outlet pipes, using exclusively sealing materials suitable for gas,
For the valves of the BFV series proceed as follows:
insert the valve between the two gaskets and tighten the flanges to the valve body by means of the respective bolts.
- 1.4 The installation of both BSV and BFV valves can be performed in any position. Anyway, the horizontal position is recommendable.
- 1.5 The valve can be installed in any location except where acid fumes or other deteriorating vapour may attack its metal parts or where gas leaks or explosive vapours are present in the atmosphere.
- 1.6 Do not use the valve as a lever.

2. OPERATING

- 2.1 Before operating the following points must be checked carefully:
external tightness of gas pipes.
that valve adjustment is performed within the requested angle range.
that mechanical locks or other retainers, which may damage the valve, have been removed.
- 2.2 Once these preliminary checks have been performed, the main gas tap can be opened and the operation test can be carried out.

3. MAINTENANCE AND CHECKS

- 3.1 The BSV and BFV valves do not require any particular current maintenance because they do not need lubrication.
- 3.2 It is recommendable to check at least once a year that the mechanical connections have not been modified, especially in case of systems which do not function vibration-free.

4. REPLACEMENT

- In case replacement of the valve is necessary, proceed as follows:
- 4.1 Close the main gas tap.
 - 4.2 Remove the mechanical connections from the valve axis.
 - 4.3 Remove the valve body from the inlet and outlet flanges by loosening the fastening screws from the respective nuts.
 - 4.4 Install the new valve proceeding as per instructions reported in the foregoing chapters.

All the reported data are subject to be changed without notice.

form140906